

TANDEMBOX – A-Design

Schubkasten / Drawer / Tiroir / Cassetto / Cajón

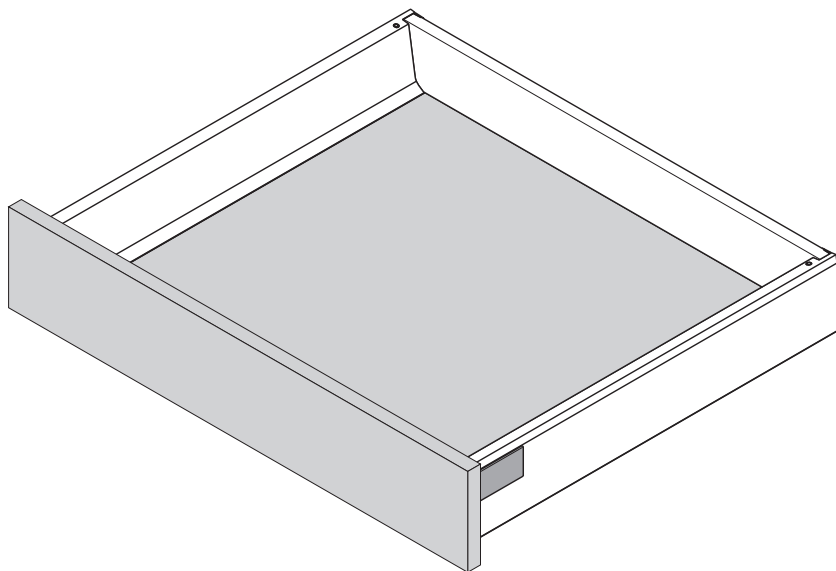

Montageanleitung

Assembly instruction

Notice de montage

Indicazioni di montaggio

Instrucciones de montaje

Platzbedarf im Korpus / Space requirements in cabinet /
 Besoin d'encombrement dans le corps de meuble /
 Ingombro nel corpo mobile / Espacio ocupado

Höhe N / height N / hauteur N /
 altezza N / altura N

Höhe M / height M / hauteur M /
 altezza M / altura M

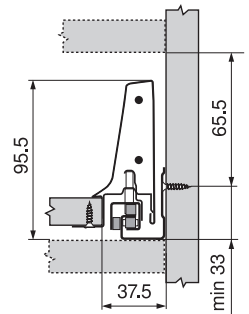
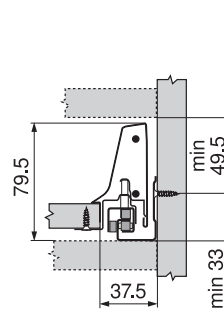

Einbaumaße Front für Schraubmontage / Installation dimensions for
 screw-on front / Cotes de montage de la face pour version à visser /
 Quote di montaggio per frontale con montaggio a vite / Cotas de
 montaje frente versión para atornillar

Höhe N / height N / hauteur N /
 altezza N / altura N

Höhe M / height M / hauteur M /
 altezza M / altura M

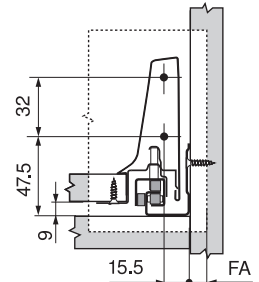
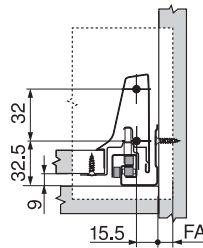

FA = Frontaufschlag / Front overlay / Recouvrement /
 Battuta anta - sormonto / Recubrimiento del frente

Einbohrmaße Front für INSERTA- und Pressmontage / Drilling
 dimensions for INSERTA and knock-in front / Cotes de perçage de
 la face pour montage INSERTA et à frapper / Quote di foratura del
 frontale per mont. INSERTA e a pressione / Cotas de taladrado
 frente montaje-INSERTA y para prensar

Höhe N / height N / hauteur N /
 altezza N / altura N

Höhe M / height M / hauteur M /
 altezza M / altura M

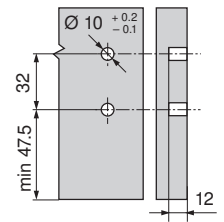
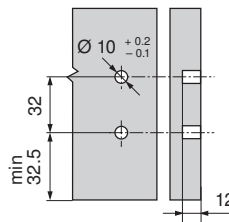

Einbaumaße Rückwand / Back installation dimensions / Cotes de
 montage du dos / Quote di montaggio schienale / Cotas de montaje
 trasera

Höhe N / height N / hauteur N /
 altezza N / altura N

Höhe M / height M / hauteur M /
 altezza M / altura M

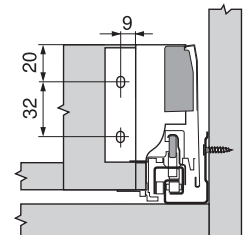
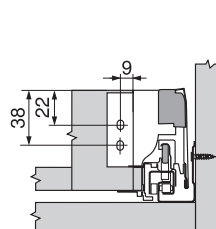

Zuschnittmaße für 16 mm Spanplatten / Cutting dim. for 16 mm chip-
 board / Débits des panneaux de 16 mm / Misure del taglio per pan-
 nelli di truciolato da 16 mm / Cotas de corte tableros aglo de 16 mm

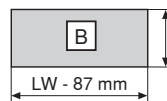

Rückwand / Back / Dos / Schienale / Trasera

Höhe N / height N / hauteur N / altezza N / altura N
 69 mm

Höhe M / height M / hauteur M / altezza M / altura M
 84 mm

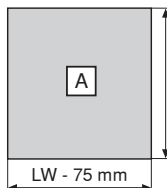

Boden / Base / Fond / Fondo / Fondo

Holzrückwand / Chipboard back

/ Dos bois / Schienale in legno /

Trasera en madera

NL - 24 mm

Stahlrückwand / Steel back / Dos

acier / Schienale in acciaio / Trasera

en acero
 NL - 22 mm

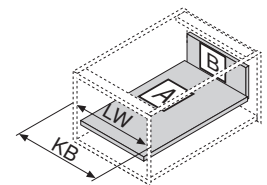

KB Korpusbreite / Cabinet Width /
 Largeur de corps de meuble /
 Larghezza corpo mobile / Ancho
 cuerpo de mueble

LW Lichte Korpusweite / Inner
 cabinet width / Largeur intérieure
 du corps de meuble / Larghezza
 interna corpo mobile / Ancho
 interior de cuerpo de mueble

NL Nennlänge / Nominal Length /
 Longueur nominale / Lunghezza
 nominale / Largo nominal

**Montage Front / assembly front/ montage de la face /
montaggio del frontale / montaje del frente**

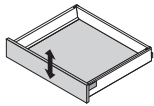
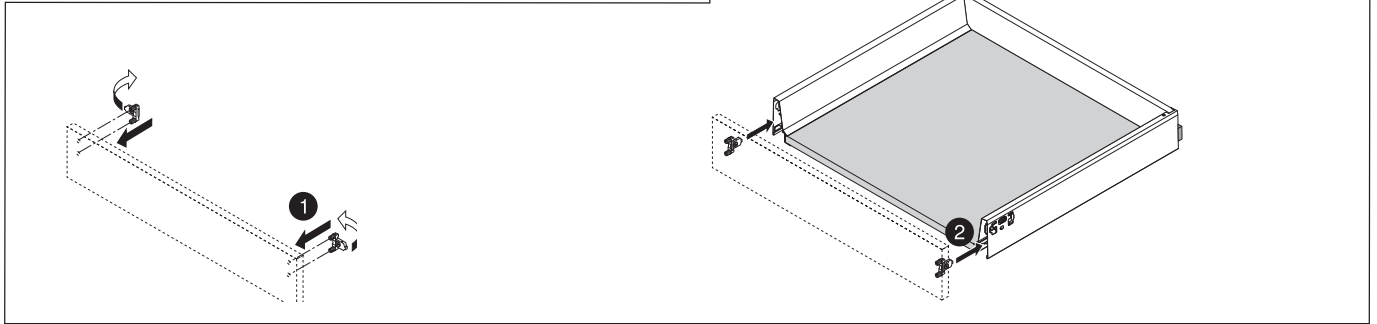

**Höhenverstellung / height adjustment /
réglage en hauteur / regolazione verticale /
ajuste en altura**

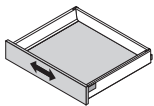
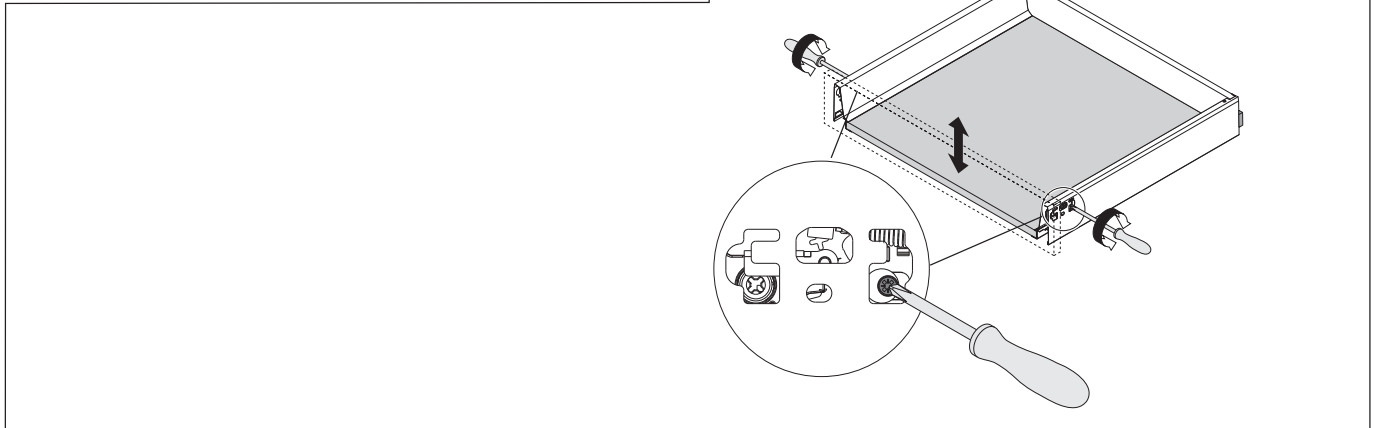

**Seitenverstellung / side Adjustment /
réglage latéral / regolazione laterale /
ajuste lateral**

Beidseitige Verstellung erforderlich. / Both sides require adjustment. /
Réglage nécessaire des deux côtés. / È necessario eseguire la regolazione
su entrambi i lati. / Es posible realizar el ajuste por ambos lados.

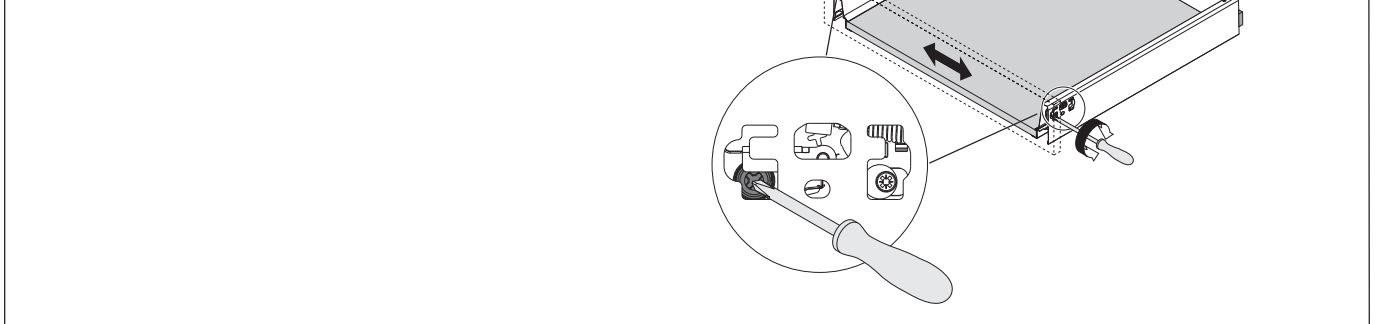

**Montage Abdeckkappe / assembly cover cap / montage du cache /
montaggio della placchetta/ montaje de la tapa**

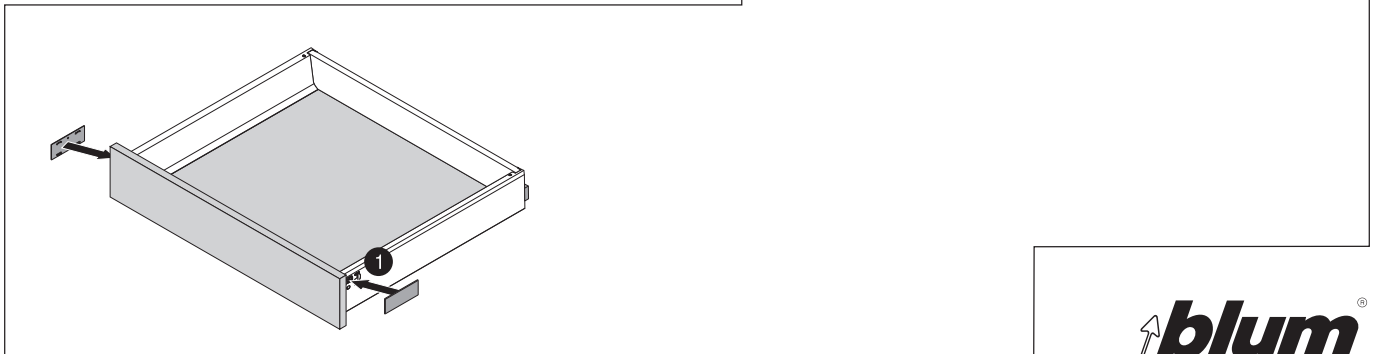

Demontage Front / removal front / démontage de la face /
smontaggio del frontale / desmontaje del frente

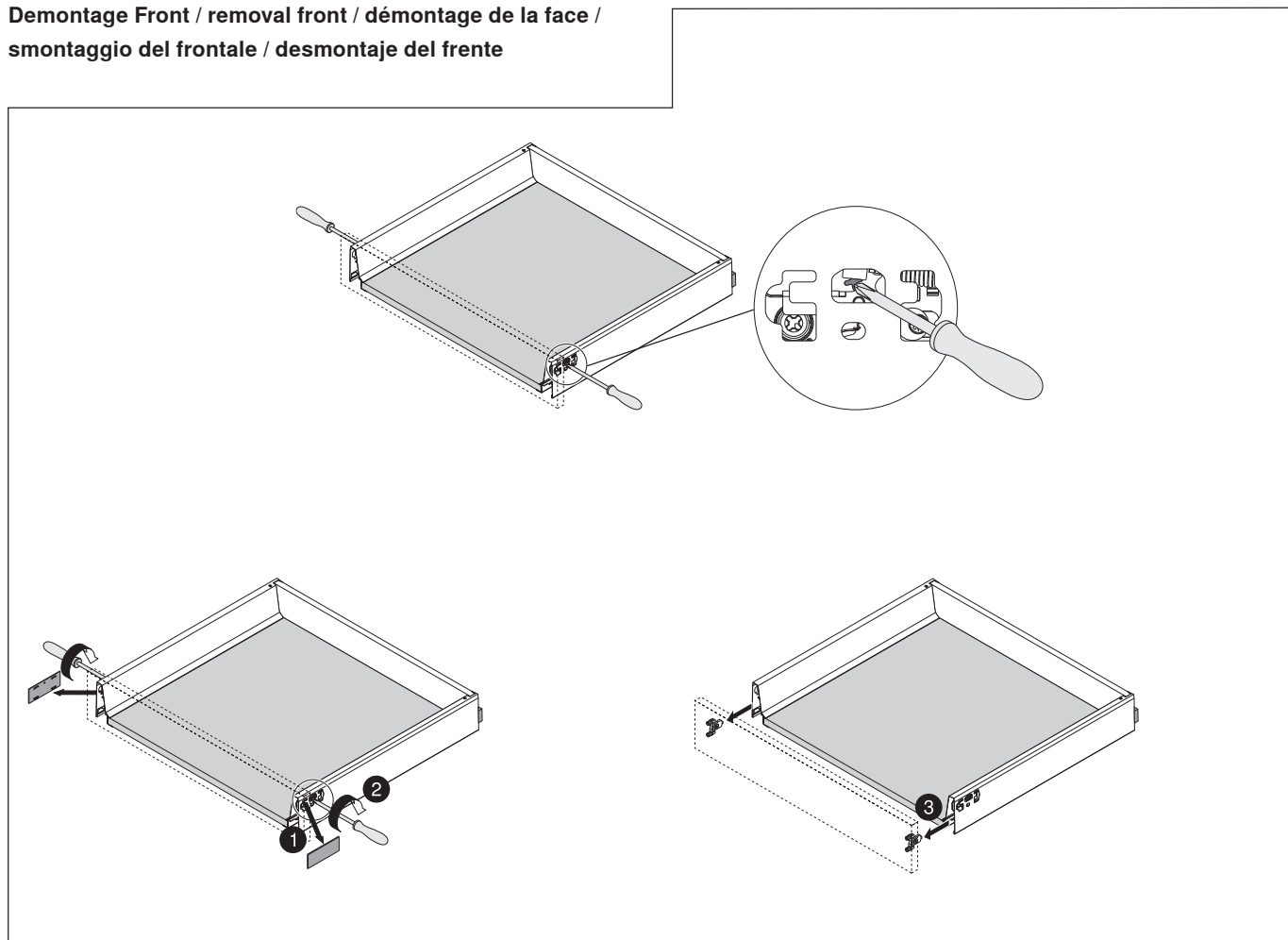

Julius Blum GmbH
Beschlägefabrik
6973 Höchst, Austria
Tel.: +43 5578 705-0
Fax: +43 5578 705-44
E-Mail: info@blum.com
www.blum.com

 **blum**[®]